

EZ CUTTER

Clean cut of tubular metallic pipes on e-line

OPERATING PRINCIPLE:

Run on E-line, the EZ Cutter is the newest award winning cutting technology that enables clean and perfectly controlled cuts without the use of explosives or chemicals. Simplifying transportation, safety and logistics issues, the EZ Cutter can be deployed on our own or third party's wireline. Its main requirement is to have conductive fluid in the well, such as brine. Different fluid compositions shall be studied on a case by case basis.

Adapted for pipe recovery or completion removal, the clean and precise cut enables considerable rig-time savings as no additional polishing is required. It is safe to fish or run any other wireline tool below the cut without risking to get stuck.

The same tool is able to cut the wider range of pipe diameters in the market, and even run through thin restrictions and cut a wider pipe below. The EZ Cutter has proven to successfully cut pipes in compression where other techniques find their limits.

The 2" 7/8 EZ Cutter can cut most grades of steel pipes ranging from 4" 1/2 to 10" 3/4.

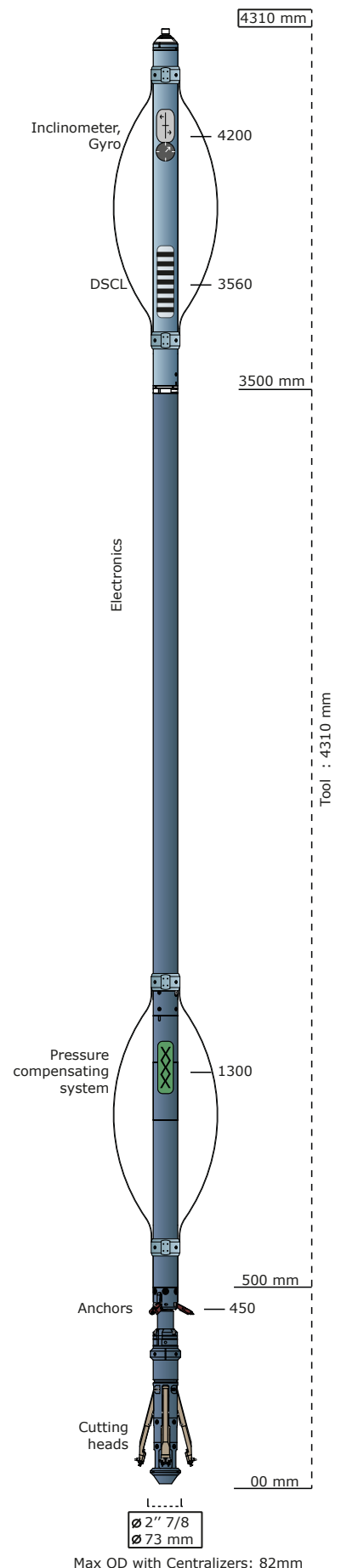

APPL ICAT IONS

- // Casing Cutting
- // Drill Pipe Cutting
- // Liner Cutting
- // Pipe Recovery
- // Plug&Abandon
- // Cavity Development
- // Multi-Layer cavity development

BEN EFI TS

- // No Chemicals
- // No Explosives
- // Clean Cut
- // Save Time
- // Save Money
- // Wide Pipe Diameter Range With Same Drift
- // Easy Fishing (No Polishing Required)

SPECIAL CONFIGURATIONS THAT EZ CUTTER CAN CUT:

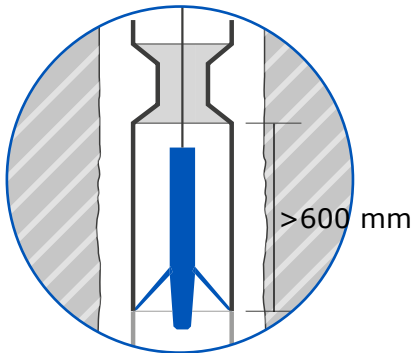

Small tool OD cuts large pipes

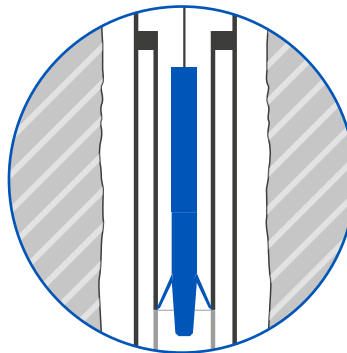

Inner pipe without affecting outer pipe

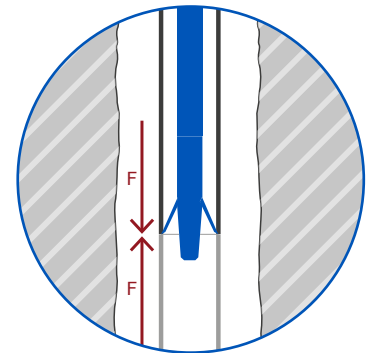

Pipes in compression

The above drawings are merely illustrative and not to scale. In all cases, the whole tool must be centered and concentric to the pipe to cut.

SPECIFICATIONS:

	imperial	metric
Max OD	2" 7/8	73 mm
Length	14,1 ft *	4,31 m
Weight	106,5 lbs *	48,3 kg
* Specifications for 7" casing configuration		
Max Temperature	175/257 °F	80/125 °C
Max Pressure	3,5/10 kpsi	250/680 bar
Material	Stainless Steel 316L / Stainless Steel 17-4PH	
Sensors	DSCL - Gyro - Inclinator	
Pipe cutting range	4" 1/2 - 10" 3/4	
Max pipe thickness	0,6 in	12 mm
Minimum Drift	3" 1/5	82 mm
Fluid in well	Conductive* (>33 000 ppm)	
Tool positioning	Centered and Coaxial to the pipe to cut	
Centralizers	At least 2, slip-over centralizers	

*Variations of conductive fluid compositions can be studied on a case by case basis